

FLONE

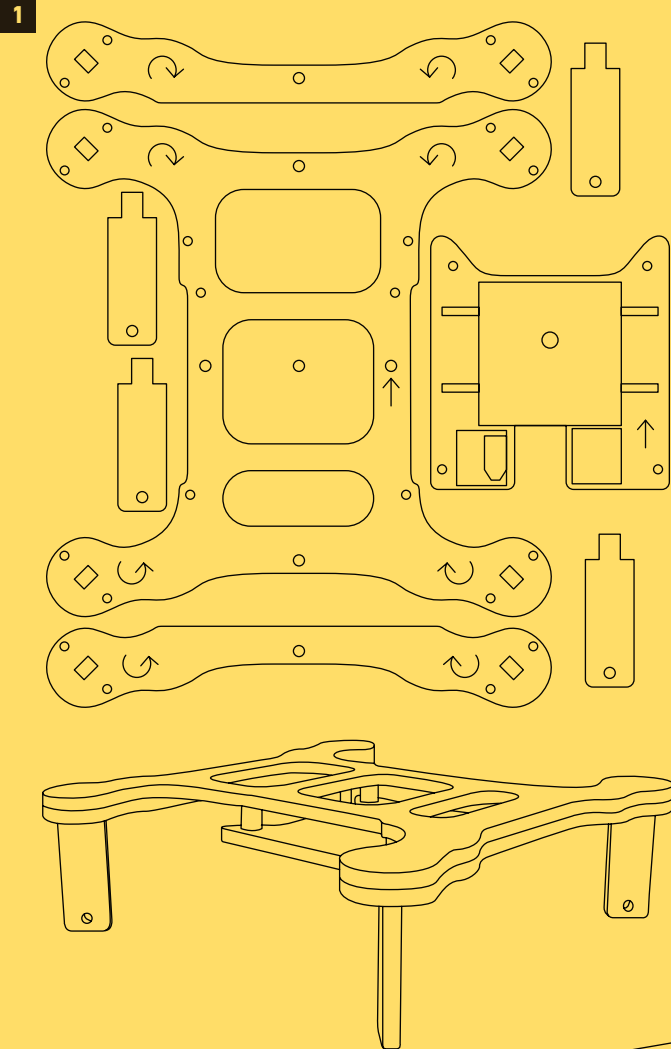

Laser-cut or jigsaw-cut the frame, using the pattern downloadable from flone.aeracoop.net. Glue the frame together (reinforcement arms, legs, electronics plate). Attach the motors with cable ties.

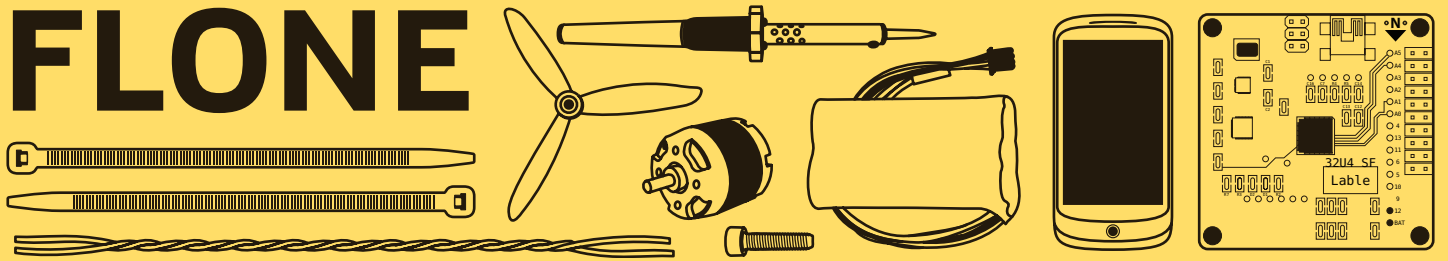
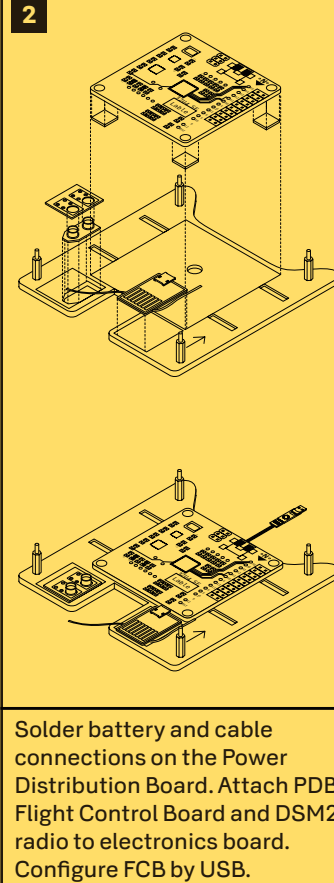

Solder battery and cable connections on the Power Distribution Board. Attach PDB, Flight Control Board and DSM2 radio to electronics board. Configure FCB by USB.

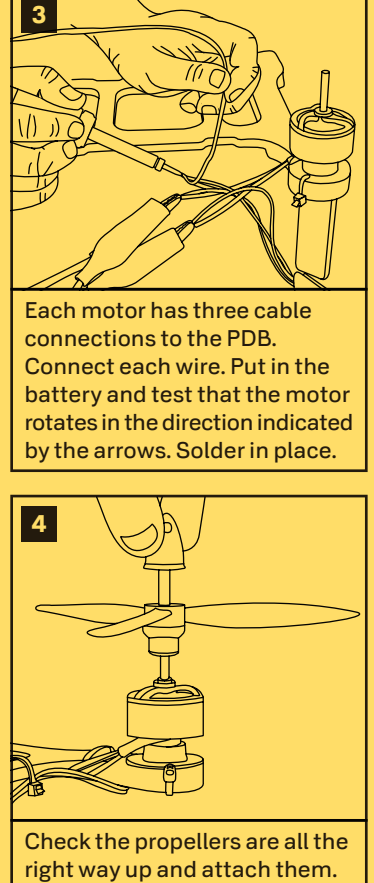

Check the propellers are all the right way up and attach them.

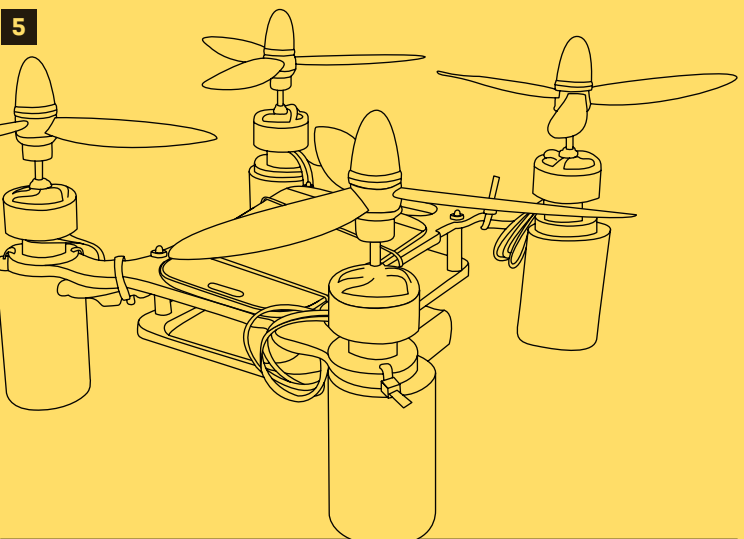

Attach sponge to protect the phone. Screw the electronics plate into place. Cable tie any loose cable, attach the battery via Velcro straps and attach foam legs for soft landings. Strap your phone in. You are ready for a test-flight.

For more detailed instructions, please visit flone.aeracoop.net